

DESCHAMPS

SINCE 1860

MOBI-CHAIR® :

ASSEMBLY, OPERATION, MAINTENANCE AND SAFETY MANUAL

DESCHAMPS_COM_MANUTIL_20220922_Manuel Mobi-Chair_UK_V1



DESCHAMPS

SINCE 1860

Usine du Bourisson - 16400 La Couronne -

France Tél. : +33 (0) 545 677 030

Fax : +33 (0) 545 678 160

www.mobi-mat.com

Foreword

Thank you for purchasing a Mobi-Chair.

This manual includes wheelchair operating limits and how you or your assistant can assemble your wheelchair, perform maintenance operations and make any adjustments.

This model is designed with benefits and features to meet customer's demands in their daily life. Grounded on rigid examination during the entire manufacturing process, your wheelchair was composed with quality components.

However, all the repairs (except for inert tubes), including some adjustments, must be executed by your distributor who possesses specific technical training.

The information mentioned in this manual is amenable to change without notice.





SUMMARY

1. Operating the wheelchair	4
a. User indications	4
2. Safety and Operating information	4
Stability.....	4
Weight Limit	4
3. Safety inspection	5
a. Performance.....	5
b. General inspection.....	5
General	5
Folding system	5
Armrests	5
Seat and backrest upholstery	5
Rear wheels	5
Castors	5
Fork.....	5
Rubber pneumatic tires	5
4. Standard Components	6
5. Assembling the chair	7
a. Rear tire installation	7
b. Front tire installation	8
c. Arm installation	9
6. Pre-use checks	11
a. Tire condition	11
b. Armrest condition	11
c. Controls.....	12
7 Maintenance	12
a. Rinse after each use	12
b. Greasing every week	12
Floating arm fixations.....	12
Inclination of the back seat.....	14
Floating arm pin.....	14
8 Specification	15
9 WARRANTY	16

1. Operating the wheelchair

The wheelchair is well suited for normal weather conditions and firm surfaces. For safety purposes, please avoid using the wheelchair in adverse weather and other poor conditions. It is forbidden to use the equipment alone. It is mandatory to be accompanied by a person in an appropriate physical and mental condition in order to respond to an emergency.

a. User indications

Operating the wheelchair may injure the user or damage the wheelchair if the user is unable to have full control. It is forbidden to use the equipment alone. It is mandatory to be accompanied by a person in an appropriate physical and mental condition in order to respond to an emergency.

2. Safety and Operating information

This manual references the most common procedure. Techniques of safe operation and maintenance of the wheelchair are mentioned as well. In order to handle your wheelchair safely, please follow all detailed instructions given in the manual.

Stability

Your wheelchair has been designed to provide the stability you need during normal daily activities. Therefore, proper operation of your wheelchair will maintain balance at all times. The impact on the position of the center of gravity is under any wheelchair movement. A change in the center of gravity may lead to the wheelchair tipping over and a fall. When you move or transfer your weight from one place to another, we recommend using seat belts to improve your safety.

Weight Limit

The maximum limitation weight of the user is 135 kg.

CAUTION !

- Do not use parts that can be detached, such as armrests, for support or any other reasons other than the intended purposes. Do not use them as a means for lifting the product, as they may be inadvertently released. This may result in injury to the user and / or attendant.

CAUTION !

- Avoid turning suddenly and never try to climb and descend a ramp diagonally.

3. Safety inspection

a. Performance

As the user, any possible operational defects of your wheelchair will be noticed by you first. The easiest troubleshooting symptoms to identify and the preliminary inspection that you can perform are indicted in the following table. You should consult your retailer if the symptoms persist after adjusting the pressure in the tires and tightening screws and nuts.

b. General inspection

The responsibility of any wheelchair repairs belongs to your distributor with qualified, technical expertise. We suggest a complete inspection by your retailer at least once a year. Regular maintenance helps the identification and replacement of defective and worn parts on your wheelchair. This also allows the improvement of daily operation.

General

Make sure that the wheelchair folds and unfolds easily and smoothly.
Check that the wheelchair moves in a straight line. (No resistance or deviation)

Folding system

Check the folding system for worn or distorted parts.

Armrests

Make sure that the armrests are firmly attached and in good condition. Check the pressure of the armrest.

Seat and backrest upholstery

Make sure that the upholstery is in good condition.

Rear wheels

Make sure that the wheel nuts and precision bearings are tight.
Check that the wheels are parallel to the frame.

Castors

Make sure that the axle is tight by turning the wheel. The wheel must gradually come to a stop.

Fork

Make sure that all the fittings are well tightened.

Rubber pneumatic tires

Check the pressure of the pneumatic tires (value indicated on the side).

CAUTION !

- Although the Mobi-Chair can float on water, you cannot use or treat it as a boat. In normal condition of use, the Mobi-Chair will not turn over if the user sits sturdily. However, for safety and requirement by law, a life jacket is to be worn by the user. The Mobi-Chair is not intended for areas with currents or strong waves.

Please be sure to use Mobi-Chair in a range in which the lifeguard can reach timely. Be careful and have fun!

4. Standard Components

- A. Chair Frame (1)
- B. Floating armrest (2)
- C. Rear tires (2)
- D. Front tire (1)

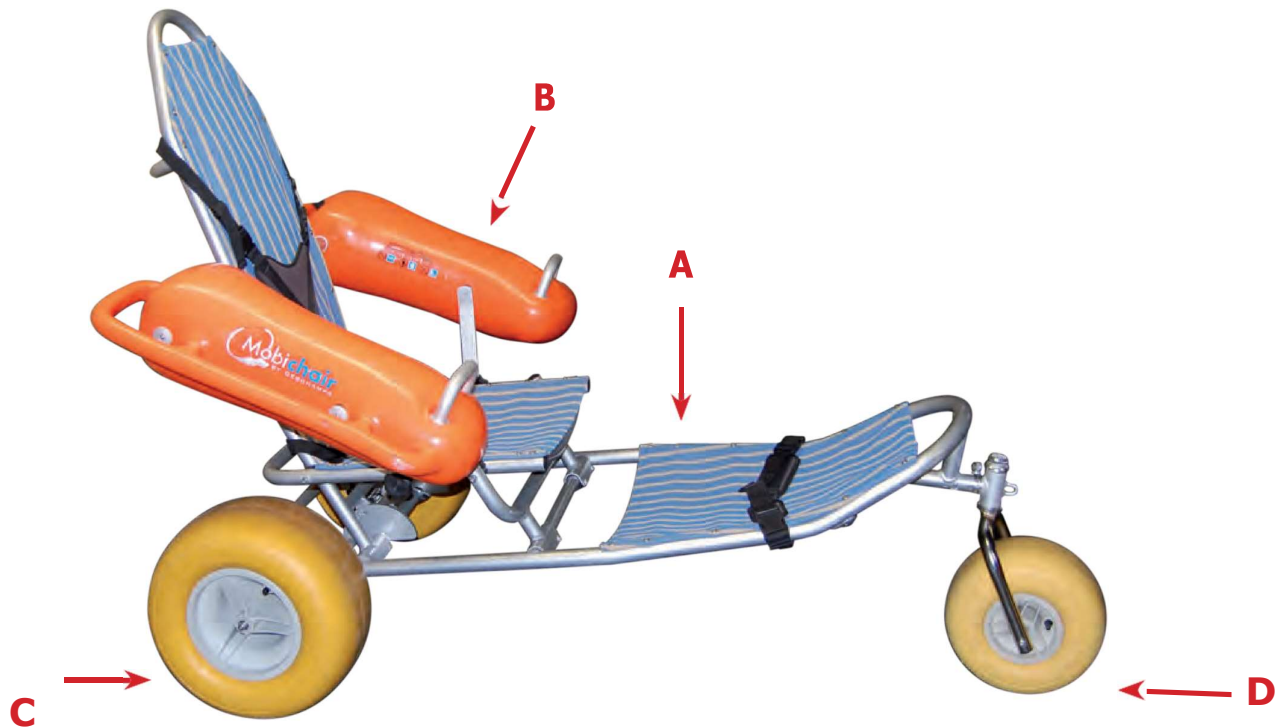

5. Assembling the chair

a. Rear tire installation

- Lay the chair frame on the ground such that the back of the chair and the Mobi- Chair logo are facing up.

**To fold the chair, pull the chain located under the seat and push the back of the chair forward.*

- Align the two large tires with the chair frame by sliding the screw springs into the opening on the plate of each tire

- Slightly tighten the springs.

**If the screws are too tight, the lever will not lock.*

- Push back the lever to lock tires in place

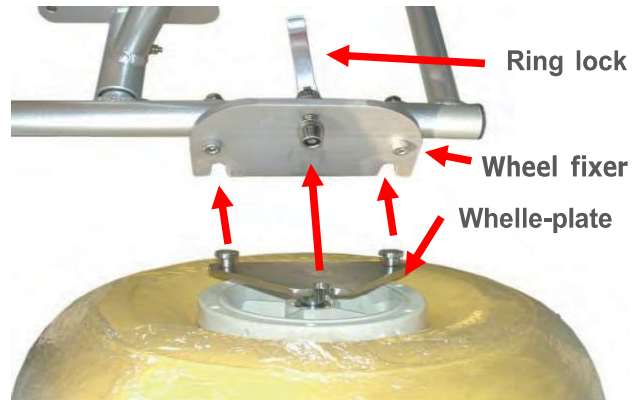
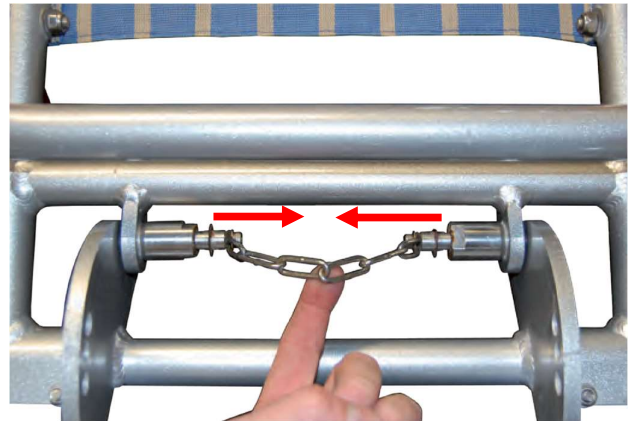

b. Front tire installation

- Insert rod of the small tire into the front of the chair frame



- Make sure the pin is properly aligned in the chair frame.

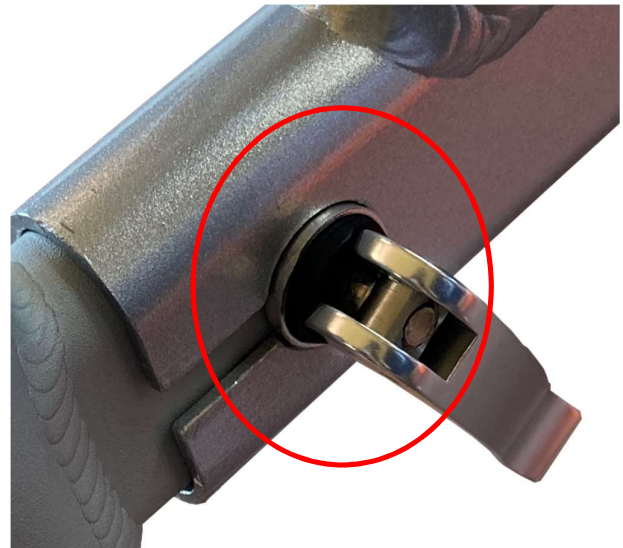

- Screw and push back the lever to lock front tire in place.



c. Arm installation

- Open chair frame in upright position
- Insert back rod on armrest into the backrest of the chair frame by pressing down the pins. Make sure the pins are aligned properly and secure
- Turn the black knob on the seat of the chair to create an opening for the front of the armrest
- Insert the support rod of the armrest into the opening
- Tighten the black knob to secure the arm-rest

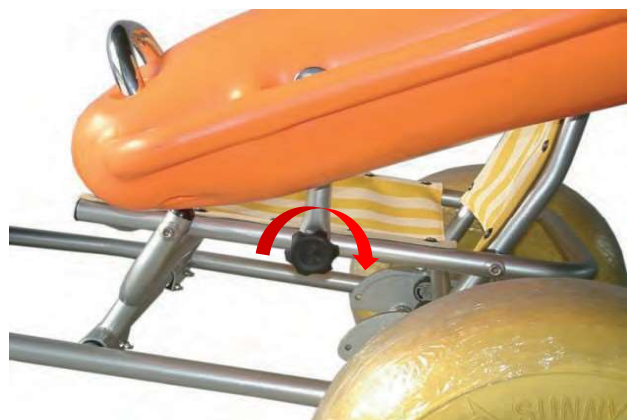
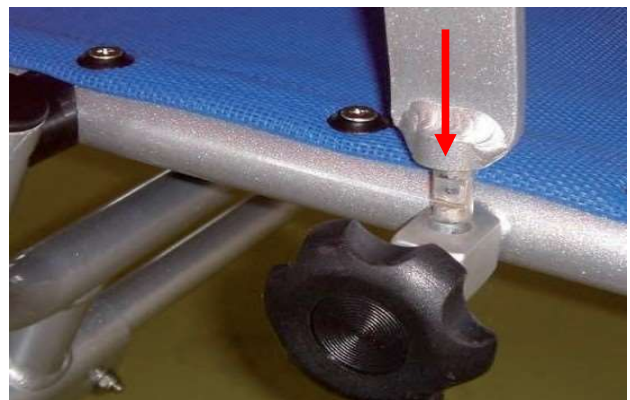
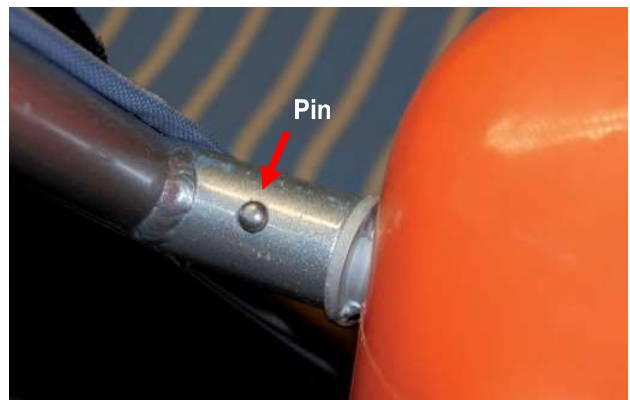

INSTALLATION COMPLETE



***STORING THE MOBI-CHAIR:** You can easily store the Mobi-Chair without removing all of the components.

- To close the chair for storage, simply detach the front of the armrests by unscrewing the black knobs located near the seat.
- Swing the Armrests back, keeping them attached to the backrest of the chair frame.
- Pull the chain located under the seat and push the backrest forward to fold the Mobi-Chair.

6. Pre-use checks

Failure to carry out these checks before using the product may result in damage to the beach wheelchair and/or injury to the user.

Before using, please check the following points:

CAUTION !

- If there are any faults or malfunctions, do not use the beach wheelchair and contact your retailer.

a. Tire condition

Tire pressures are affected by changes in temperature and altitude. Check and adjust them whenever you are using the chair in areas where there are large variations in temperature or altitude.

Check the user weight and adjust a suitable tire pressure that is not over the maximum pressure mentioned below.

Maximum front rubber pneumatic tire pressure: **7 psi – 48.2 kpa**

Maximum rear rubber pneumatic tire pressure: **7 psi – 48.2 kpa**

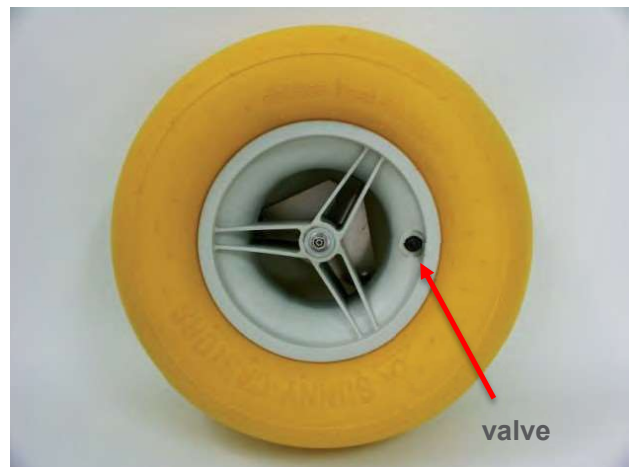
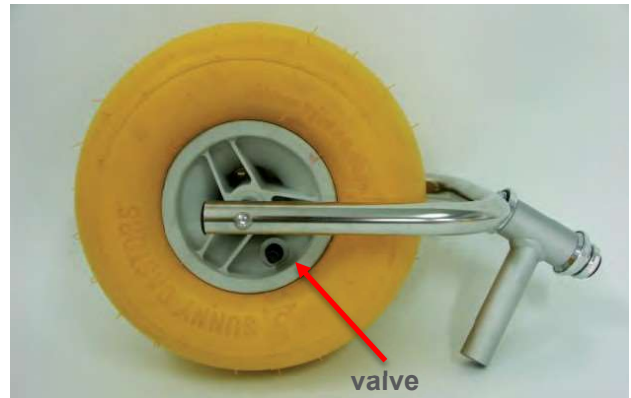

b. Armrest condition

Check the armrest conditions and make sure it is not punctured or releasing any air.

Do not inflate the armrest over 17.78 cm (7") in armrest center thickness as photo shown on right.

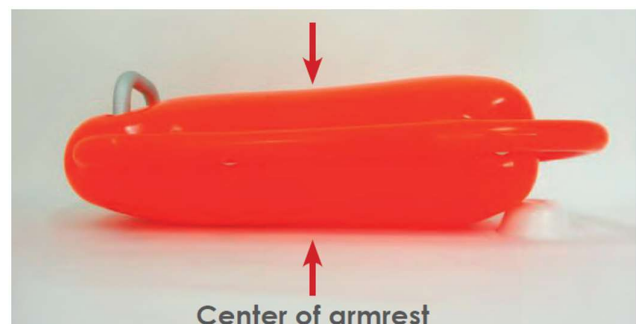

c. Controls

Check the frame, fork, folding system and tire/armrest condition and ensure that they function correctly.

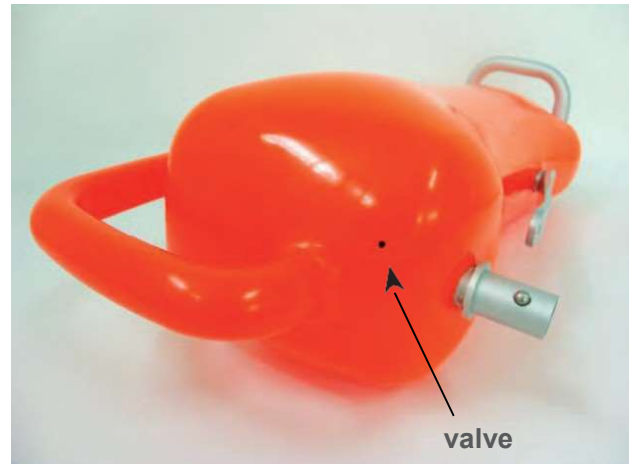

7 Maintenance

a. Rinse after each use

To ensure that your mobi-chair stays in good condition, the mobi-chair should be rinsed with fresh water after EVERY use. The connecting plates and rods must be rinsed thoroughly to remove all sand, salt and dirt from the mobi-chair. Failure to clean the connecting parts of the mobi-chair may result in creating forms of corrosion of the product.

b. Greasing every week

To ensure that your mobi-chair stays in good condition, some points should be greased with grease as WD-40, multi-purpose oil or white lithium grease.

Floating arm fixations

Both armrest fixation should be greased every week to ensure that the product remains in good condition.



- 1) Loosen the knob in order to show the thread, and squeeze a small amount of grease onto the thread.



- 2) Then tighten the knob. By tightening the knob, the grease will spread inside the housing and on the thread.



- 3) Loosen up the safety screw located on the housing of the floating arm chair and insert a few drops of oil. Be careful: Tighten the safety screw back.



- 4) Loosen up the black knob, remove the metal support by pulling upward and pour some grease into the housing.



- 5) Put back the metal support and tighten the black knob



Inclination of the back seat

Both armrest fixation should be greased every week to ensure that the product remains in good condition.



- 1) Push the back seat forward to have a better access to the chain and its housing and squeeze some oil into each end of the moving parts



Floating arm pin

- 1) Pull out the floating arm, and spread the grease around the entire rod. Re-insert the rod into the housing.



8 Specification

Item	Specification
Model	Mobi-Chair®
Frame	Folding aluminum frame & stainless fork and hardware, salt water resistant
Seat Width	46 cm (18»)
Seat Depth	43 cm (17»)
Seat Height	48 cm (19»)
Product Length	153 cm (60»)
Product Width	105 cm (41»)
Product Height	127 cm (50»)
Product Weight	35 KGS (77 LBS)
Armrest	PVC Flip Up & Detachable Floating Armrest
Front Castor	12" x 6-1/2" Rubber Pneumatic Tire*1 w/quick release
Rear Wheel	16" x 7-1/2" Rubber Pneumatic Tire*2 w/quick release
Seat fabric	Non-Allergic, UV Resistant, Water Resistant Ventilated
Backrest	4 sections adjustable
Weight Capacity	135 KGS (300 LBS)

- (1) Non-Allergic, UV Resistant' Water Resistant Ventilated
 (2) 3 Sections (Per 10°) Angle Adjustable 110°~130°
 (3) PVC flip Up & Detachable Floating Armrest



No.	Item No.	Material
1	Frame	a Aluminium b Aluminium & Stainless
2	Armrest	c PVC d Aluminium ☆(3)
3	Front Wheel 12"	Rubber & PA+GF
4	Rear Wheel 16"	Rubber & PA+GF
5	Seat Fabric	PVC ☆(1)

Weight Capacity 135Kgs (300lbs)
 Product Weight 27.4Kgs (60lbs)

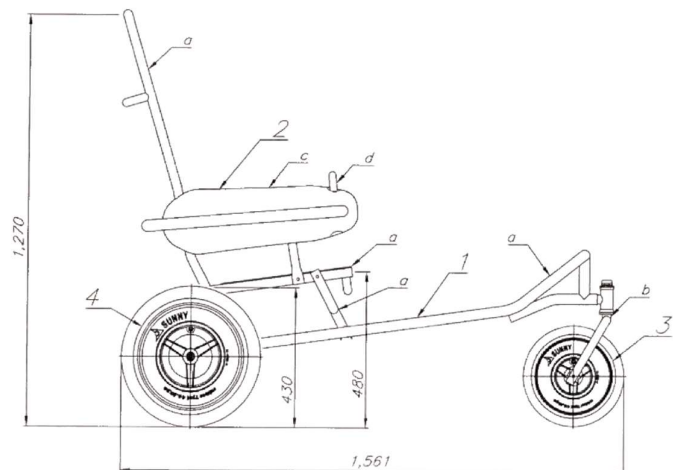
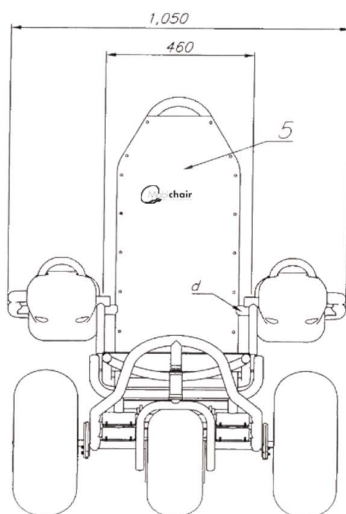

9 WARRANTY

Thank you for purchasing our product. To ensure the validity of your one (1) year warrantee, please ask your dealer to fill in the form below.

Product Name:		Model No.:	Product Label:
Name:		Tel.:	
E-mail:			
Address:			
Serial Number:			
Date of Purchase:	Dealer confirmation Shop stamp		
Dealer : Tel.: () Shop Name: Address:			

Condition:

With regards to the original purchaser/user only, Mobi-Chair warrants the frames to be free from defects in materials and workmanship for a period of one (1) year from date of purchase; all remaining components for one (1) year from the date of purchase except upholstered materials, padded materials and tires/wheels. This warranty does not include any labor or shipping charges incurred for replacement, part installation or repair of any such product. Mobi-Chair's sole obligation and your exclusive remedy under this warranty shall be limited to such repair and/or replacement. For warranty service, please contact the dealer from whom you purchased your Mobi-Chair product. In the event you do not receive satisfactory warranty service, please write directly to Mobi-Chair at the address on the last page of the instruction manual. Provide the dealer's name and address, date of purchase, indicate the nature of the defect and, if the product is serialized, indicate the serial number. Do not return our products to our factory without our prior consent.

LIMITATIONS AND EXCLUSIONS: THE FOREGOING WARRANTY SHALL NOT APPLY TO SERIAL NUMBERED PRODUCTS IF THE SERIAL NUMBER HAS BEEN REMOVED OR DEFACED, PRODUCTS SUBJECT TO NEGLIGENCE, ACCIDENT, IMPROPER OPERATION, MAINTENANCE OR STORAGE, COMMERCIAL OR INSTITUTIONAL USE, NATURAL DISASTER, PRODUCTS MODIFIED WITHOUT MOBI-CHAIR'S EXPRESS WRITTEN CONSENT INCLUDING, BUT NOT LIMITED TO, MODIFICATION THROUGH THE USE OF UNAUTHORIZED PARTS OR ATTACHMENTS; PRODUCT DAMAGED BY REASON OF REPAIRS MADE TO ANY COMPONENT WITHOUT THE SPECIFIC CONSENT OF MOBI-CHAIR, OR TO A PRODUCT DAMAGED BY CIRCUMSTANCE BEYOND MOBI-CHAIR'S CONTROL, AND SUCH EVALUATION WILL BE SOLELY DETERMINED BY MOBI-CHAIR. THE WARRANT SHALL NOT APPLY TO PROBLEMS ARISING FROM NORMAL WEAR OR FAILURE TO ADHERE TO THESE INSTRUCTIONS. A CHANGE IN OPERATING NOISE, PARTICULARLY RELATIVE TO MOTORS AND GEARBOXES DOES NOT CONSTITUTE A FAILURE. ALL SUCH DEVICES WILL EXHIBIT A CHANGE IN OPERATING NOISE DUE TO AGING.



Notes



Notes



Notes



ETS A.DESCHAMPS ET FILS
Usine de Bourisson
16400 La Couronne – FRANCE
+33 (0) 545 677 030
CAGE code: FA7J0

info@mobi-mat.com

www.mobi-mat.com

DESCHAMPS MATS SYSTEMS
218 Little Falls Road, Unit 12
Cedar Grove NJ 07009 – USA
+1 973 928 3040
CAGE code: 3N2Z7

Property of ETS A.DESCHAMPS ET FILS and DESCAMPS MATS SYSTEMS INC. Mobi-mat® is a registered trademark of

ETS A.DESCHAMPS ET FILS and DESCAMPS MATS SYSTEMS INC. All rights reserved. Non contractual pictures.

Products and specifications can be changed without prior notice